

Genset control

Data sheet

KEA 320 / KEA 320 RP & KEA 320 Lite / KEA 320 RP Lite



KEA 320 is also available for back panel installation, optionally with touch screen remote panel.

General

Genset controls of KEA 320 series are used in standard as well as complex applications for emergency power generation. The successor of reliable KEA 200 provides a significantly extended scope of functions based on an industry-leading system platform. KEA 320 (Lite) complies with all current standard specifications for emergency power applications. Equipped with a comprehensive pre-configuration KEA 320 is the ideal compact genset control for generator packagers and system integrators.

KEA 320 (Lite) includes specifically designed algorithms and logic to start, stop, control, and protect the genset, circuit breaker and the utility, where applicable. It allows standardizing on a single, affordable genset controller for distributed power generation applications. The applications range from single stand-alone emergency backup power to parallel load sharing of multiple gen-sets in complex, segmented distribution systems with multiple utility feeds and tie breakers.

The versatile KEA 320 sets new standards in power management and parallel operation of gensets. At island or parallel operation mode load sharing of up to 32 gensets can be realized with a single utility. KEA 320 combines complete engine-generator control and protection with advanced, peer-to-peer paralleling functionality and innovative features in a robust, attractive, user-friendly and all-in-one package.

Its integrated programmable logic functionalities provide outstanding application flexibility and can often eliminate the need of an additional PLC control, yet can easily integrate with SCADA or PLC-based control systems where desired. Enhanced connectivity enables fast and secure interfacing to other controls and communications systems.

KEA 320 (Lite) also comes without a display in a rugged metal housing suitable for back panel installations. A sophisticated touch screen remote panel complements it as an operator control panel.

Function overview

- Standard paralleling#1 applications for up to 32 generators in
- Peak shaving operation
- Stand-by operation
- AMF (Automatic Mains Failure) operation
- Emergency operation
- Import/Export operation
- Islanded & Utility parallel operation
- Microgrids / Hybrid plants
- Easy to set up and commission
- Master or Slave control capability
- Complete engine, generator and utility protection
- Synchronization logic
- Five communication ports: Ethernet, 2xCAN (CANOpen and J1939), RS-485, USB
- Customizable logic, HMI screens, and alarms
- Dedicated low temperature display variants
- UL 61010-, UL 6200-, 2011/65/EU-conform and marine compliant (ABS, LR)

#1 Parallel connection of up to 32 generators is not available with the KEA 320 Lite

Easy-to-use software tools simplify configuring the genset controls of KEA 3X0 series while making it easy to customize the unit for specific applications.

FlexApp – This feature provides the tools to easily configure the number of operated breakers: None, Generator Circuit Breaker (GCB), and Mains Circuit Breaker (MCB).

LogicsManager & AnalogManager (LM & AM) – LM/AM enables to customize the operation sequences and adapt them to specific needs. The LM/AM accomplishes this by handling a range of measuring values and internal states, which are combined logically with operators and programmable timers and can be cascaded through. This enables to create and/or modify control and relay functions.

FlexIn – The analog inputs are configurable to operate with variable resistance sensors (0 to 2000 Ω), (0 to 1V) and/or 0 to 20 mA senders.

Flexible Outputs – Speed and voltage bias outputs are configurable to function with all speed governors and voltage regulators. The outputs can also be used as freely scalable outputs (e.g. for driving external meters).

FlexCAN – Advanced network interfaces ensure unsurpassed control performance – from engine control up to total plant operation. The KEA 3X0 series is capable of working with common industrial interfaces, including Ethernet, CAN, USB, and RS-485. The multiple communication protocols permit the KEA 3X0 series controls to communicate with a vast majority of engine control units (ECUs), external I/O boards, and PLCs. Modbus TCP, CANopen, SAE J1939, and Modbus RTU are supported.

DynamicsLCD – The adaptive and interactive 5.7", 320x240 pixel sharp color graphical LCD display with soft keys and a clear menu structure ensures intuitive user operation and navigation. Customizable screens provide flexibility to program and visualize frequently used data at the press of a button. The face plate with tactile and illuminated buttons enhances the aesthetics and ergonomics of push button operation.

Features

- Three-phase true RMS power sensing with Class I accuracy
- Operation modes: AUTO, STOP, MANUAL, and TEST modes accessible through face plate or discrete input
- Breaker control: Slip frequency/phase matching synchronization, open/close control, breaker monitoring
- Load transfer: open/closed transition, interchange, soft loading/unloading, Utility parallel
- Load share^{#1} and device to device communication over Ethernet or CAN ("warm redundancy" possible)
- Remote control via interface (Modbus TCP, Modbus RTU) and via discrete/analog inputs for adjusting speed, frequency, voltage, power, reactive power, and power factor set points
- Freely configurable PID controllers for various control purposes, such as heating circuit control (CHP applications), water level, fuel level, pressure and/or other process values
- Direct support to several ECUs: Scania S6, MTU ADEC ECU7/8, Volvo EMS2 & EDC4, Deutz EMR2 & EMR3, MAN MFR/EDC7, SISU EEM, Cummins and Woodward EGS02 ECU
- Field ECU support and additional I/O expansion board connectivity through sequencer files
- "System Update" function for online troubleshooting and adding / removing generator sets
- Time/Date synchronization over Simple Network Time Protocol (SNTP)
- Cylinder head/exhaust temperature monitoring (Temperatures come from J1939 or CANopen devices)
- ToolKit software for flexible setup from a single connection to the network. The ToolKit can be accessed either via USB, or via Ethernet, or via CAN port.

Multi-lingual capability: English, German, Spanish, French, Italian, Portuguese, Japanese, Chinese, Russian, Turkish, Polish, Slovakian, Finnish, Swedish

#1 Load sharing and P2P communication between the devices via Ethernet or CAN is not available with the KEA 320 Lite

KEA 320 Application example - for single and genset parallel operation

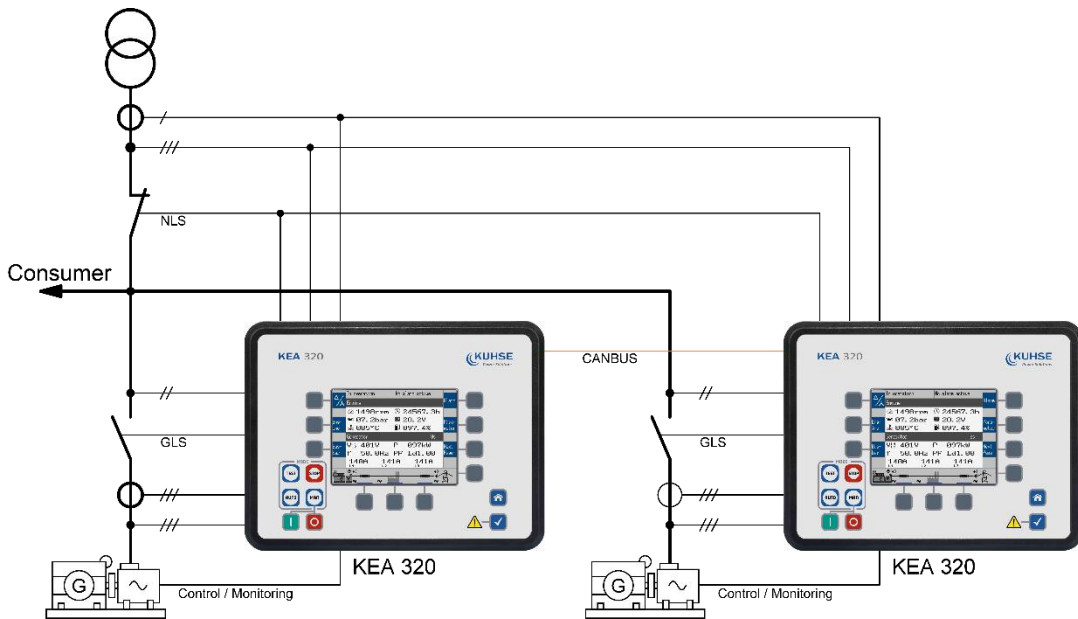

KEA 320 Lite Application example - for single gensets only

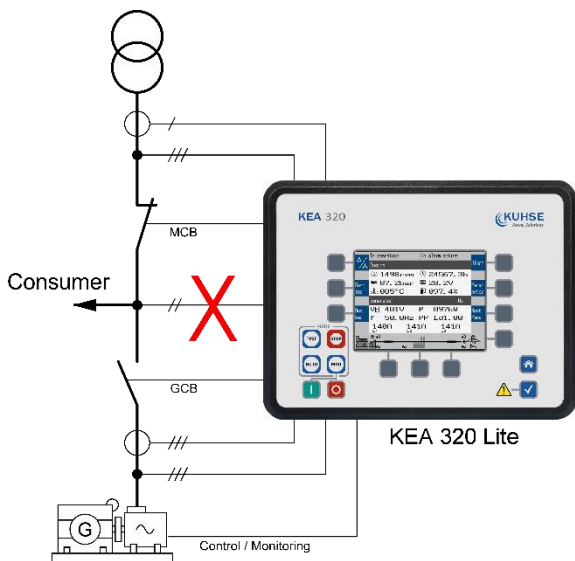

Related products

- Engine Speed Control actiVgen (Product Specification # 03419): P/N 2DVGEN0000
- Remote Panel RP 300 (Product Specification # 37592): P/N 2A300R0701
- ToolKit (Product Specification # 03366)
- I/O Expansion Board IKD1 (Product Specification # 37171): P/N 2RIKD1M000
- I/O Expansion Board IKD-IN-16: P/N 2RIKD16DIO
- I/O Expansion Board IKD-OUT-16: P/N 2RIKD16DOO
- Load Share Gateway LSG (Product Specification #. 37451)
- Electronic Pickup Unit EPU-100 (Product Specification #. 37562): P/N 2DEPU10000
- CANbus based Remote Annunciator easYlite 100 (Product Specification #. 37279): P/N 2A300REL06
- Power Generation Learning Module (Product Specification #. 03412): P/N 2SPGLM0000
- Profibus Gateway ESEPRO (Application Note # 37577): P/N 2GESEPRO00
- Ethernet (Modbus/TCP) Gateway ESENET (Application Note # 37576): P/N 2GESENET00
- Profinet-Gateway P/N S135000756
- SNMP-Gateway P/N S135000762
- BACnet-Gateway P/N S135000773
- CANbus to Fiber Optic Converters (Application Note # 37598):
DL-CAN P/N 2GDLCANS00 and DL-CAN-R P/N 2GDLCANR00
- Remote Gateway
- Thermocouple Scanner AXIOMATIC AXTC20
- WAGO and Phoenix expansion CAN couplers

Technical Data

General	
Power supply	12/24 VDC (8 to 40 VDC)
Intrinsic consumption	max. 14 W (LT: max.22W)
Ambient temperature (operation)	-20 to 70 °C (LT: -40 to 70 °C)
Ambient temperature (storage)	-30 to 80 °C / -22 to 176 °F
Ambient humidity	95%, non-condensing
Voltage (software configurable)	(λ/Δ)
100 Vac Rated (V_{rated})	69/120 V_{AC}
Max. value (V_{max})	86/150 V_{AC}
and 400 Vac Rated (V_{rated})	277/480 V_{AC}
Max. value (V_{max})	346/600 V_{AC}
Rated surge volt. (V_{surge})	4.0 kV
Accuracy	Class 0.5
Measurable alternator windings	3p-3w, 3p-4w, 3p-4w OD, 1p-2w, 1p-3w
Setting range primary	50 to 650,000 V_{AC}
Linear measuring range	1.25× V_{rated}
Measuring frequency	50/60 Hz (40 to 85 Hz)
High Impedance Input; Resistance per path	2.0 MΩ
Max. power consumption per path	< 0.15 W
Current (Isolated, software configurable)	
Rated (I_{rated})	1A or 5A
Linear measuring range	$I_{gen} = 3.0 \times I_{rated}$ $I_{mains/ground} = 1.5 \times I_{rated}$
Setting range	1 to 32,000 A
Burden	< 0.10 VA
Rated short-time overcurrent (1 s)	[1] 50× I_{rated} , [5] 10× I_{rated}
Accuracy	Class 0.5
Power	
Setting range	0.5 to 99,999.9 kW/kvar
Accuracy	Class 1.0
Discrete inputs	isolated
Input range	12/24 V_{DC} (8 to 40 V_{DC})
Input resistance	approx. 20 kOhms
Relay outputs	isolated
Contact material	AgCdO
Load (GP)	2.00 A_{AC} @250 V_{AC} , 2.00 A_{DC} @24 V_{DC} / 0.36 A_{DC} @125 V_{DC} / 0.18 A_{DC} @250 V_{DC}
Analog inputs (isolated)	freely scalable
Type	0 to 1V / 0 to 2000 Ohms / 0 to 20 mA
Resolution	16 Bit
Maximum permissible voltage against genset Ground	9 V
Maximum permissible voltage between genset Ground & PE	100 V

Analog outputs (isolated)	freely scalable
Type	$\pm 10\text{ V} / \pm 20\text{ mA} / \text{PWM}$
Basic insulation voltage (continuously, AVR_{out})	500 V_{AC}
Reinforced insulation voltage (continuously, AVR_{out})	300 V_{AC}
Insulation voltage (continuously, Gov out)	100 V_{AC}
Resolution	12 Bit
$\pm 10\text{ V}$ (scalable)	internal resistance
$\pm 20\text{ mA}$ (scalable)	maximum load 500 Ohms
Housing Front panel flush mounting	Plastic housing
Dimensions WxHxD	282 × 216 × 96 mm
Front cutout WxH	249 [+1.1] × 183 [+1.0] mm
Connection	screw/plug terminals 2.5 mm ²
Front	insulating surface
Sealing	
Front	IP66 (with screw fastening)
Front	IP54 (with clamp fastening)
Back	IP20
Weight	approx. 1,850 g
Housing Back panel mounting	Powder Coated Sheet metal housing
Dimensions WxHxD	250 × 227 × 50 mm
Connection	screw/plug terminals 2.5 mm ²
Protection system	IP 20
Weight	approx. 2,150 g
Disturbance test (CE)	tested according to applicable IEC standards
Listings	CE, UL, EAC, VDE-AR-N-4105/4110, CSA, CUL
Marine	LR (Type Approval), ABS (Type Approval)

Dimensions

Plastic housing for front panel mounting

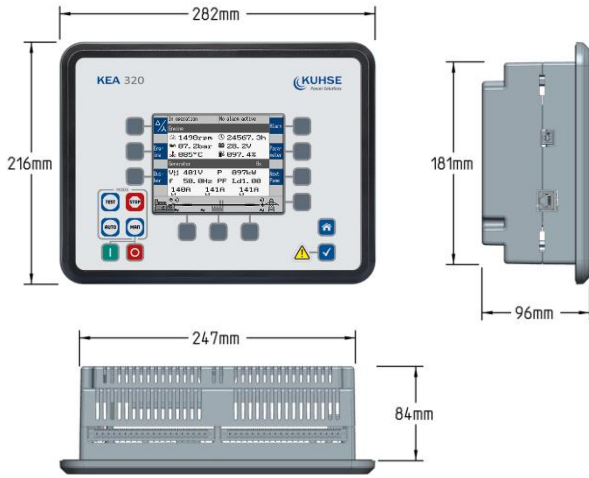

Metal housing for cabinet mounting

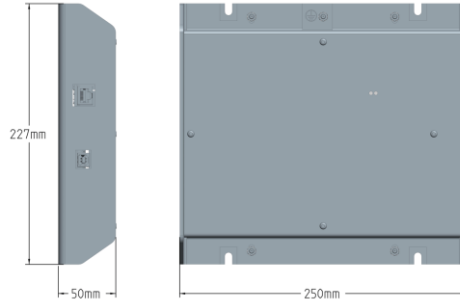

Remote Panel

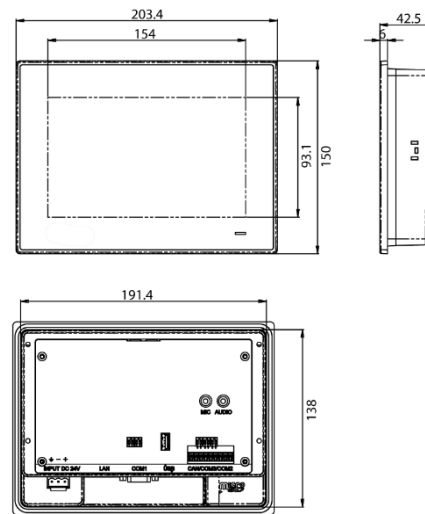

Terminal diagram

Mains Gnd Current AC 1 A 5 A		Generator Current AC 1 A 5 A						Analog Inputs 0 to 2 kOhm 0/4 to 20 mA 0 to 1 V							Analog Outputs ±10 Vdc ±20 mA PWM				
s2	s1	L1	s2	s1	L2	s2	s1	L3	s2	s1	AI 01	AI 02	AI 03	Engine Ground	AO 01	AO 02	NC	AO 02	
-	+	-	+	-	+	-	+	-	+	-	+	-	+	-	+	-	+	-	
1	2	3	4	5	6	7	8	9	10	11	12	13	14	15	16	17	18	19	20

Mains Voltage AC 120 V 480 V ph-ph								Generator Voltage AC 120 V 480 V ph-ph								Busbar Voltage AC 120 V 480 V ph-ph			
NC	L1	NC	L2	NC	L3	NC	N	NC	L1	NC	L2	NC	L3	NC	N	NC	L1	NC	L2
21	22	23	24	25	26	27	28	29	30	31	32	33	34	35	36	37	38	39	40

* Pin 37 - 40
KEA 320 RP Lite & KEA 320 Lite:
No connection

60	59	58	57	56	55	54	53	52	51	50	49	48	47	46	45	44	43	42	41
R12	R11	R10	R09	R08	R07	R06	R05	R04	R03	R02	R01								

Relay Outputs

80	79	78	77	76	75	74	73	72	71	70	69	68	67	66	65	64	63	62	61
MPU	D112	D111	D110	D109	D108	D107	D106	D105	D104	D103	D102	D101	Common DI	Auxiliary Excitation D+	+	+	NC	*	

Discrete Inputs

* Pin 61
KEA 320 RP-P1: No connection
KEA 320-P1: Protective earth

Function overview

Variant	320 RP Lite	320 Lite	320 RP	320
Package	P1	P1 (-LT) ^{#6}	P1	P1 (-LT) ^{#6}
Measuring				
Generator voltage (3-phase/4-wire)	120 / 480 V AC		120 / 480 V AC	
Generator current (3x true r.m.s.)	1 / 5 A		1 / 5 A	
Mains voltage (3-phase/4-wire)	120 / 480 V AC		120 / 480 V AC	
Mains or ground current (1x true r.m.s); Mains or ground current (selectable)	1 / 5 A		1 / 5 A	
Busbar voltage	-		2-phase	
			120 / 480 V AC	
Control				
Generator breaker control	✓		✓	
Mains breaker control	✓		✓	
Generator group breaker	-		-	
Run-Up Synchronization	-		-	
No of supported LS-5-devices ^{#5} (1 or 2 breaker controls)	-		-	
Breaker control logic (open and closed transition <100 ms)	2		2	
Automatic, Manual, Stop, and test operating modes	✓		✓	
Single and multiple-unit operation	-		✓	
Mains parallel multiple-unit operation (up to 32 units)	-		✓	
AMF (auto mains failure) and stand-by operation	✓		✓	
Critical mode operation	✓		✓	
GCB and MCB synchronization (±slipping / phase matching)	✓		✓	
Import / export control (kW and kvar)	✓		✓	
Load-dependent start/stop	-		✓	
n/f, V, P, Q, and PF control via analog input or interface	✓		✓	
Load/var sharing for up to 32 gensets	-		✓	
Freely configurable PID controllers	3		3	
HMI				
Display	remote	integrated	remote	integrated
Color Display with Softkey operation	-	✓	-	✓
Start/stop logic for diesel / gas engines	✓		✓	
Counters for operating hours / starts / maintenance / active/reactive energy	✓		✓	
Configuration via PC (serial connection and ToolKit software (included))	✓		✓	
Event recorder entries with real time clock (battery backup)	1000		✓	
Operating Temperature	-40 to 70 °C	(-40/)-20 to 70°C	-40 to 70 °C	(-40/)-20 to 70°C

Variant		320 RP Lite	320 Lite	320 RP	320
Package		P1	P1 (-LT) ^{#6}	P1	P1 (-LT) ^{#6}
Protection	ANSI				
Generator: voltage / frequency	59/27/810/81U	✓		✓	
Generator: overload, reverse/reduced power	32/32R/32F	✓		✓	
Generator: Synch Check	25	✓		✓	
Generator: unbalanced load	46	✓		✓	
Generator: instantaneous overcurrent	50	✓		✓	
Generator: time-overcurrent (IEC 255 compliant)	51/51V	✓		✓	
Generator: ground fault (measured ground current)	50G	✓		✓	
Generator: power factor	55	✓		✓	
Generator: rotation field		✓		✓	
Engine: overspeed / underspeed	12/14	✓		✓	
Engine: speed / frequency mismatch		✓		✓	
Engine: D+ auxiliary excitation failure		✓		✓	
Engine: Cylinder temperature		✓		✓	
Mains: voltage / frequency / synch check	59/27/810/81U/25	✓		✓	
Mains: phase shift / rotation field / ROCOF (df/dt)	78	✓		✓	
Busbar: voltage/frequency/rotation field		-		✓/✓/-	
I/Os					
Internal digital I/O expansion board		-		-	
Speed input: magnetic / switching; Pickup		✓		✓	
Battery voltage monitor		1		1	
Discrete alarm inputs (configurable)		12 (10)		12 (10)	
Discrete outputs, configurable		max. 12		max. 12	
External discrete inputs / outputs via CANopen		32/32		32/32	
Analog inputs ^{#1} , configurable		3		3	
Analog outputs: +/- 10V, +/- 20mA, PWM; configurable		2		2	
Analog outputs: 0-20mA, (0-10V with external 500 Ω resistor)		-		-	
External analog inputs / outputs via CANopen		16 / 4		16 / 4	
Display and evaluation of J1939 analog values, "supported SPNs"		100		100	

Variant	320 RP Lite	320 Lite	320 RP	320
Package	P1	P1 (-LT) ^{#6}	P1	P1 (-LT) ^{#6}
I/Os (interfaces)				
CANbus communication interfaces ^{#2, #3}	2 ^{#7}		2	
Ethernet Modbus TCP Slave interface ^{#3}	1		1	
USB Serial interface	1		1	
RS-485 Modbus RTU Slave interface	1		1	
Parameterization via USB or Ethernet interface	✓		✓	
Listings/Approvals				
CE Marked, VDE-AR-N 4105/4110, EAC	✓		✓	
Part Numbers				
Front panel mounting with display ^{#4}	-	2A320CS101	-	2A320CS100
Cabinet back mounting without display	2A320RS101	-	2A320RS100	-
Spare connector kit	2A320PS100	2A320PS100	2A320PS100	2A320PS100

- #1 selectable senders: VDO (0 to 180 Ohm, 0 to 5 bar), VDO (0 to 180 Ohm, 0 to 10 bar), VDO (0 to 380 Ohm, 40 to 120°C), VDO (0 to 380 Ohm, 50 to 150°C), Pt100, Pt1000, resistive input (one- or two-pole, 2pt. linear or 9pt. user defined)
- #2 CAN#2 freely selectable during configuration between CANopen or J1939; please feel free to request more information
- #3 It is possible to toggle between CAN and Ethernet load share line in STOP mode ("warm redundancy")
- #4 a screw and a clamp kit are delivered with the unit for fastening
- #5 the KEA 320 Lite has 2 CAN-Bus interfaces, the communication with other KEAs (load dependent power up/down and active/reactive power distribution) is not available.
- #6 controllers with the addition "-LT" are low-temperature versions down to -40°C, Kuhse delivers these units only with the Woodward front cover